

CREATOR Electronics

VGA Matrix Switchers System

User Manual

Please read this manual carefully before using this product.

Notice:

This **VGA Matrix Switchers User Manual** takes example of the Matrix model VGA0808. It can be used as user's manual of other VGA matrix switcher models. This manual is only an instruction for operators, not for any maintenance usage. Any changes of functions and parameters since then will be informed separately. Please refer to the dealers for the latest details.

All product function is valid till 2010-12-31

 **Safety Operation Guide**

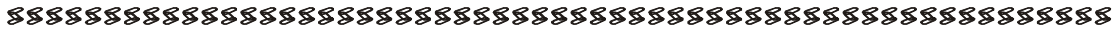

In order to ensure the credibility use of the product and the user's safety, please comply with the following items during installation and maintenance:

①

The system must be earthed properly. Please do not use two blades plugs and ensure the alternating power supply ranged from 100v to 240v and from 50Hz to 60Hz.

②

Do not put the switcher in a place of too hot or too cold.

③

To avoid any damage by over heat, please keep the working environment good in ventilation to radiate the heat when running the switcher.

④

The switchers should be turned off when in rainy and humid days or nonuse for a long time,

⑤

The alternating power supply line should be disconnected with the power socket during the following operation.

- A. Take out or reinstall any component of the switcher
- B. Disconnect or re-connect any connector of the switcher

⑥

Please do not attempt to maintain and uncover the switcher for there is a high-voltage component inside and the risk of the electric shock.

⑦

Do not splash any chemical product or liquid on or near the equipment.

Contents

1. INTRODUCTION.....	5
1.1 ABOUT VGA MATRIX SWITCHER SYSTEM.....	5
1.2 VGA MATRIX SWITCHER MODELS	5
2. PACKING OF THE PRODUCT.....	6
3. INSTALLATION	6
4. FRONT VIEW OF THE PRODUCT	7
4.1 FRONT VIEW OF THE VGA0404-A	7
4.2 FRONT VIEW OF THE VGA0801	7
4.3 FRONT VIEW OF THE VGA1601, VGA3201	7
4.4 FRONT VIEW OF THE VGA0802-A,VGA0804-A,VGA0808-A.....	7
4.5 FRONT VIEW OF THE VGA1604-A,VGA1608-A	8
5. REAR VIEW OF THE PRODUCT.....	8
5.1 REAR VIEW OF THE VGA0404-A	8
5.2 REAR VIEW OF THE VGA0801.....	8
5.3 REAR VIEW OF THE VGA1601,VGA3201	8
5.4 REAR VIEW OF THE VGA0802-A,VGA0804-A,VGA0808-A	9
5.5 REAR VIEW OF THE VGA1604-A,VGA1608-A	9
6. EXTERNAL CONNECTION	10
6.1 INTRODUCTION OF THE INPUT AND OUTPUT CONNECTORS.....	10
6.2 CONNECTION OF RS-232 COMMUNICATION PORT	10
6.2.1 <i>Connection with Control Systems.....</i>	<i>10</i>
6.2.2 <i>Connection with Computer.....</i>	<i>10</i>
6.3 HOW TO CONNECT WITH THE INPUT AND OUTPUT TERMINALS.....	11
6.4 HOW TO CONNECT WITH THE VGA I/O DEVICES	12
6.5 CONNECTION OF VGA3201 STACK.....	13
7. OPERATION OF THE CONTROL PANEL.....	13
7.1 FRONT PANEL DESCRIPTION.....	13
7.1.1 <i>Front Panel Description of VGA0404-A.....</i>	<i>13</i>
7.1.2 <i>Front Panel Description of VGA0801</i>	<i>14</i>
7.1.3 <i>Front Panel Description of VGA3201,VGA0808-A, VGA1608-A</i>	<i>14</i>
7.2 COMMAND FORMAT OF THE SWITCHING OPERATION	15
7.3 EXAMPLES OF OPERATION.....	15

8. USAGE OF THE REMOTE CONTROLLER (OPTIONAL ACCESSORY)	18
9. OPERATION OF THE SWITCHER APPLICATION	19
9.1 INTRODUCTION OF SWITCHER 2.0	19
9.1.1 <i>About the Application</i>	19
9.1.2 <i>Starting the Application</i>	19
9.2 FUNCTIONS OF THE APPLICATION	19
9.2.1 <i>Interface Description</i>	20
9.2.2 <i>Description of SYSTEM Tab</i>	20
9.2.3 <i>Description of KEYBOARD Tab</i>	21
9.2.4 <i>Description of Auto Tab</i>	21
9.2.5 <i>Description of Custom Code Tab</i>	22
9.2.6 <i>Description of Code Group Tab</i>	23
9.2.7 <i>Description of Send/receive Code List Tab</i>	24
10. COMMUNICATION PROTOCOL AND COMMAND CODES	26
11. TECHNICAL SPECIFICATIONS	29
12. TROUBLESHOOTING & MAINTENANCE	31

1. Introduction

1.1 About VGA Matrix Switcher System

VGA series Matrix switcher is a high-performance professional computer and audio signal switcher that can be used for cross switching of multi computer and audio signal.

VGA series switcher mostly apply in broadcasting TV engineering, multi-media meeting room, big screen display engineering, television education, command control center or other fields. It provides power-fail locale protection function, LCD displaying, shortcut selecting and saving function. With RS232 interface, it can be worked with PC, remote control system and any other far-end control system devices . The user manual takes VGA0808 as the example; other models can take reference from it too.

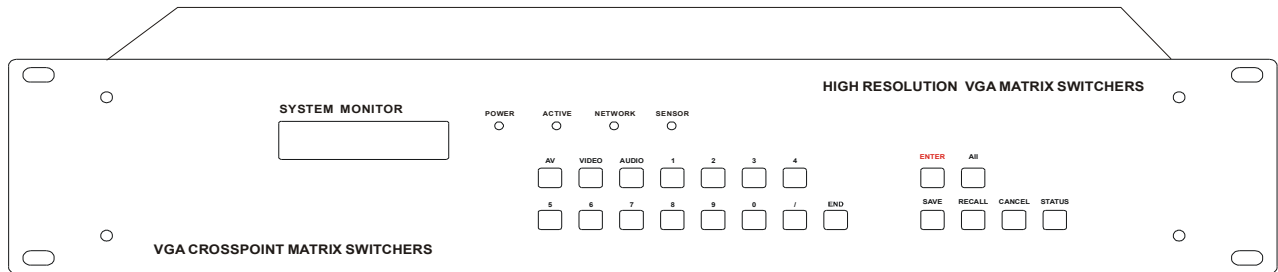

F 1-1 VGA 0808

1.2 VGA Matrix Switcher Models

According to different situation and users, the VGA series can be classified into the following models:

Specifications Models	Video Inputs	Video Outputs	RS232 Interface	Audio I/O
MATRIX VGA0801	8	1	√	×
MATRIX VGA1601	16	1	√	×
MATRIX VGA3201	32	1	√	×
MATRIX VGA0404-A	4	4	√	√
MATRIX VGA0802	8	2	√	×
MATRIX VGA0802-A	8	2	√	√
MATRIX VGA0804	8	4	√	×
MATRIX VGA0804-A	8	4	√	√
MATRIX VGA0808	8	8	√	×
MATRIX VGA0808-A	8	8	√	√
MATRIX VGA1604	16	4	√	×
MATRIX VGA1604-A	16	4	√	√
MATRIX VGA1608	16	8	√	×
MATRIX VGA1608-A	16	8	√	√

2. Packing of the Product

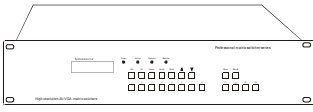

VGA Matrix Host



RS-232 Communication Cord



Power Supply Cord



CD with Application **SWITCHER 2.0**



User Manual and Quality Guarantee

3. Installation

VGA matrix switchers adopt metal shell and can be stacked with other device. Moreover, they are rack-mountable enclosure and can be installed in the standard 19" rack.

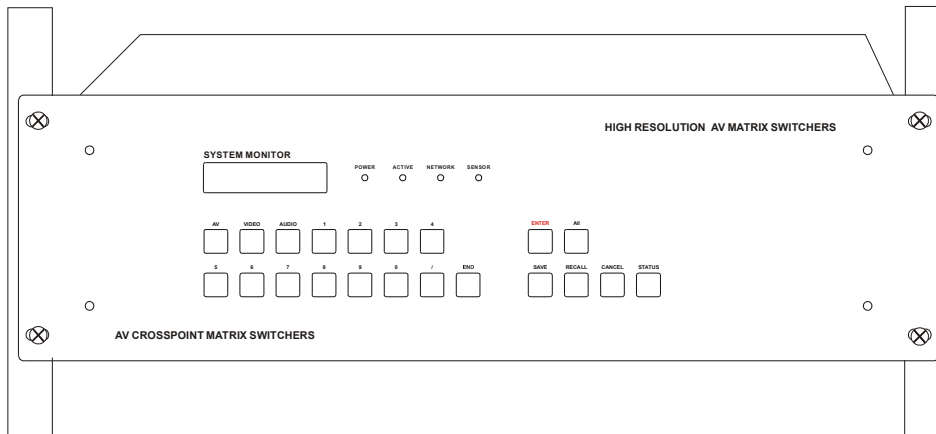

项目编号:

F 3-1 Installing the VGA matrix switcher in the standard 19" rack

4. Front View of the Product

4.1 Front View of the VGA0404-A

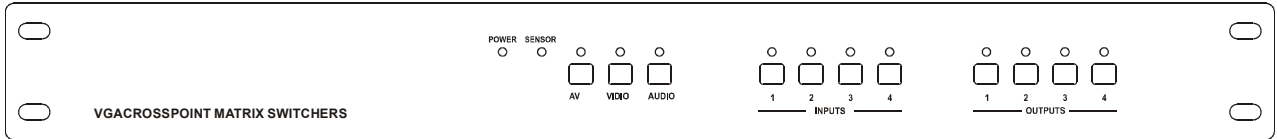

F 4-1 Front view of the VGA0404-A

4.2 Front View of the VGA0801

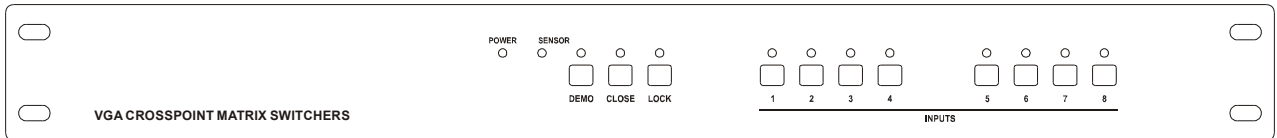

F 4-2 Front View of the VGA0801

4.3 Front View of the VGA1601, VGA3201

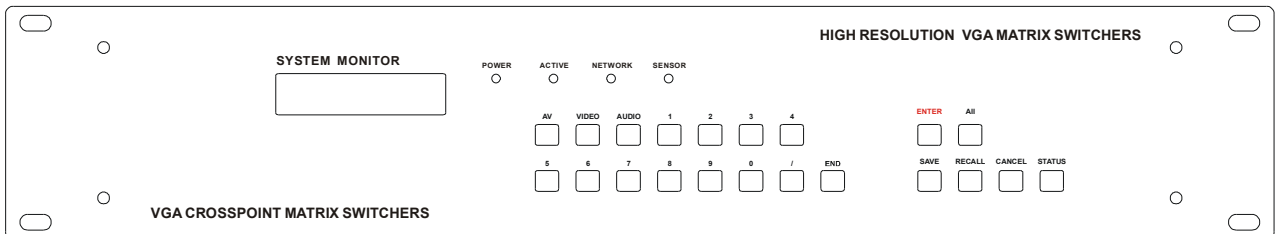

F 4-3 Front view of the VGA1601, VGA3201

4.4 Front View of the VGA0802-A, VGA0804-A, VGA0808-A

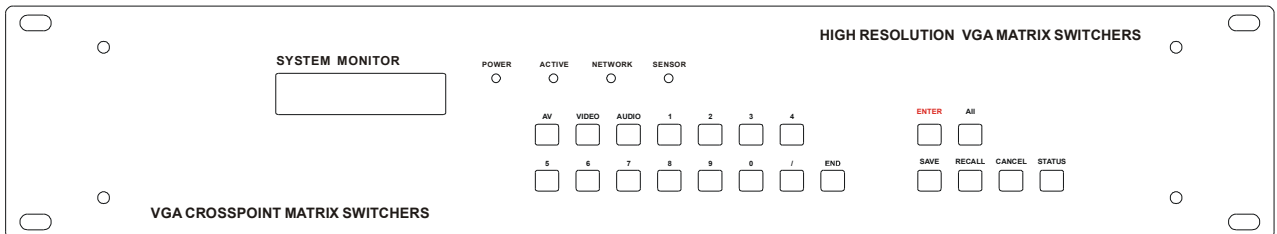

F 4-4 Front view of the VGA0802-A, VGA0804-A, VGA0808-A

4.5 Front View of the VGA1604-A,VGA1608-A

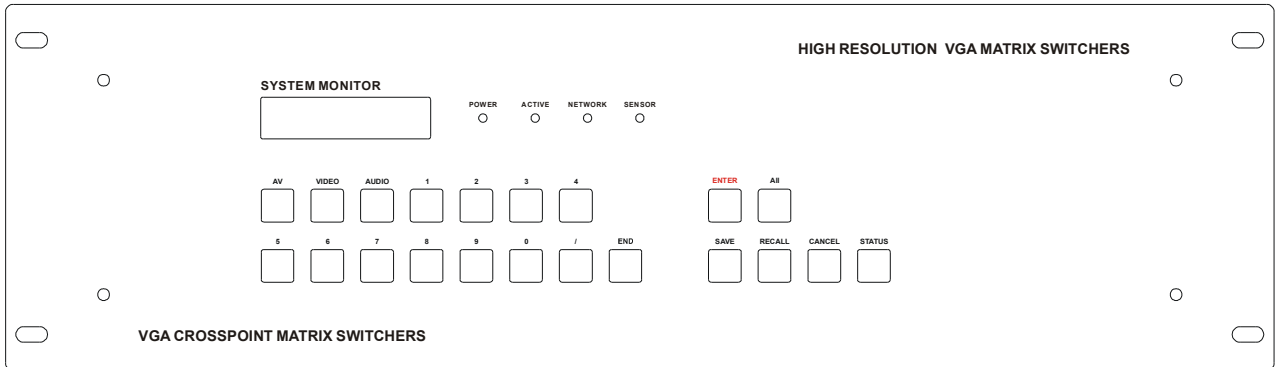

F 4-5 Front view of the VGA1604-A,VGA1608-A

5. Rear View of the Product

5.1 Rear View of the VGA0404-A

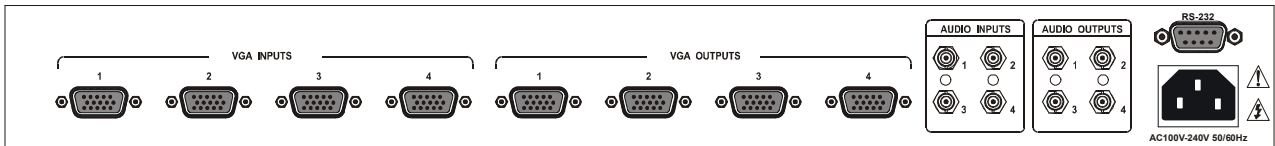

F 5-1 Rear view of the VGA0404-A

5.2 Rear View of the VGA0801

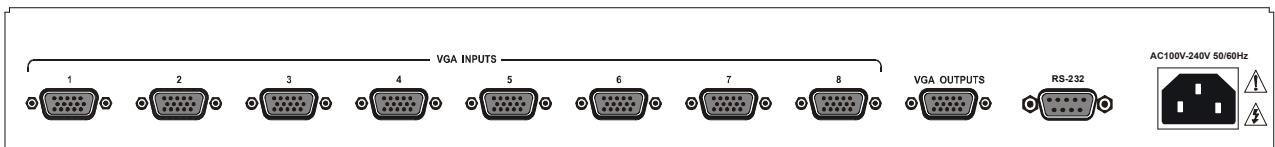

F 5-2 Rear view of the VGA0801

5.3 Rear View of the VGA1601,VGA3201

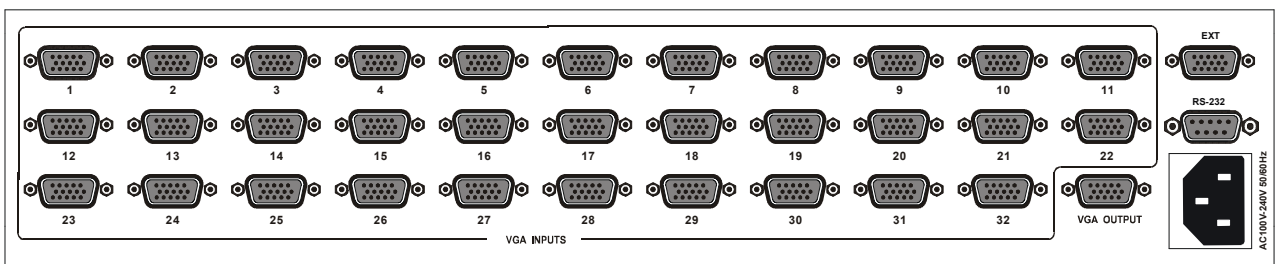

F 5-3 Rear view of the VGA1601,VGA3201

5.4 Rear View of the VGA0802-A,VGA0804-A,VGA0808-A

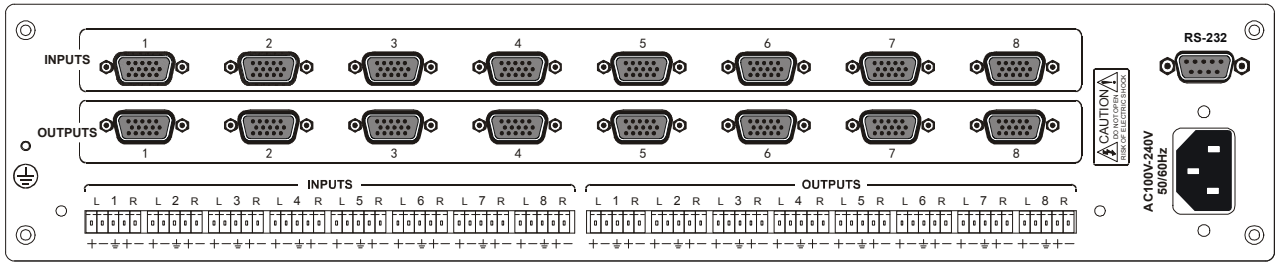

F 5-4 Rear view of the VGA0802-A,VGA0804-A,VGA0808-A

5.5 Rear View of the VGA1604-A,VGA1608-A

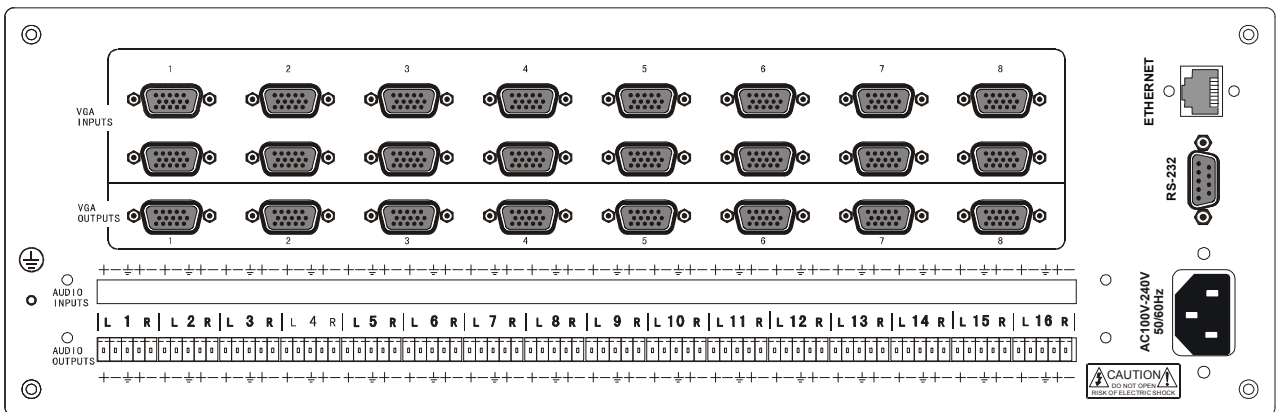

F 5-5 Rear view of the VGA1604-A,VGA1608-A

6. External Connection

6.1 Introduction of the Input and Output Connectors

The VGA matrix switchers adopt female 15-pin HD connectors as the video signal I/O interface, and captive screw connectors as the audio signal I/O interface. Please refer to the rear view figure of the model concerned for details.

6.2 Connection of RS-232 Communication Port

Except the front control panel, infrared remote controller (Optional) and the Ethernet control (Optional), the VGA matrix switcher can be controlled from far-end control systems via the RS-232 communication port.

This RS-232 communication port is a female 9-pin D connector. The definition of its pins is as the table below.

Pin	RS-232	Description
1	N/u	Not used
2	Tx	Transmit data
3	Rx	Receive data
4	N/u	Not used
5	Gnd	Signal ground
6	N/u	Not used
7	N/u	Not used
8	N/u	Not used
9	N/u	Not used

6.2.1 Connection with Control Systems

With the RS-232 port, can control and communicate with the switcher remotely.

6.2.2 Connection with Computer

When the switcher connects to the COM1 or COM2 of the computer with control software, users can control it by that computer. To control the switcher, users may use the application SWITCHER 2.0 in the supplied CD or develop their own control software with the protocol and control codes.

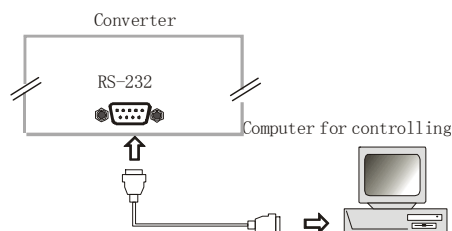

6.3 How to Connect with the Input and Output Terminals

The VGA matrix switchers may take laptops, desktop computers, graphic workstations and document cameras as their input signal source, and projectors, RP TVs, displayers and amplifiers as their output signal destinations.

VGA Connection:

The VGA matrix switchers support all kinds of the RGB and VGA signal sources with 15-PIN HD VGA connectors.

The 15-PIN HD VGA connector is shown as the figure below.

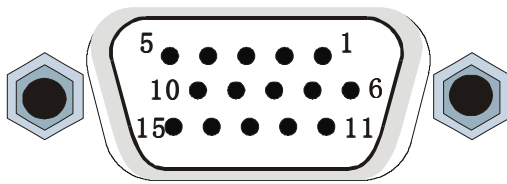

Pin	RGB	YcbCr
1	R	Cr
2	G	Y
3	B	Cb
4	Not used	
5	Ground	
6	R ground	Cr ground
7	G ground	Y ground
8	B ground	Cb ground
9	Not used	
10	Sync signal ground	
11	Not used	
12	Not used	
13	H or H/V	
14	V	
15	Not used	

F 6-2 15-PIN HD VGA connector

If the RGB device doesn't with VGA output terminals, please convert the signals with an RGB to VGA switcher for getting high quality VGA output effects.

Please use the special VGA signal cord to connect the input and output devices and connect the 15-Pin HD connectors carefully.

Audio Signal Connection:

Audio connection is little complicated than video. It has two kinds of connection: balanced and unbalanced.

The balanced connection transmits a pair of balanced signals with two signal cords. Because interferences will have the same intensity and the opposite phases on the two signal cords, it will be counteracted in the end. For the low frequency extent of the audio signal, it would be easily interfered under long distance transmission. Therefore, as an anti-interference connection, it is mostly used in audio connection of special device.

The unbalanced connection transmits signals only with a signal cord. Without counteraction, it can be interfered more easily. Accordingly, it is adopted for household appliance or some cases with low technical demand.

The two kinds of connection are shown below.

VGA Matrix Switcher System

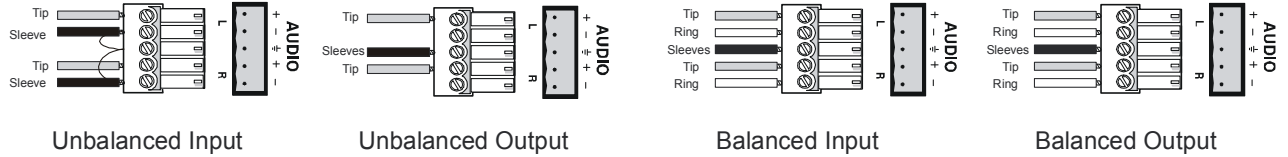

F 6-3 Balanced/unbalanced connection on captive screw connector

The connection should be selected is up to the interface of the device. When available, the balanced connection is the first choice. Before connection, please read the command or relevant demand in the user manual carefully. In some cases, maybe there is balanced in source signal end but unbalanced in the destination end. If in a nonstandard case, it is done to connect balanced for the balanced end and unbalanced for unbalanced end. But if in a standard one, the converter must be used to switch the signals as the same, balanced or unbalanced.

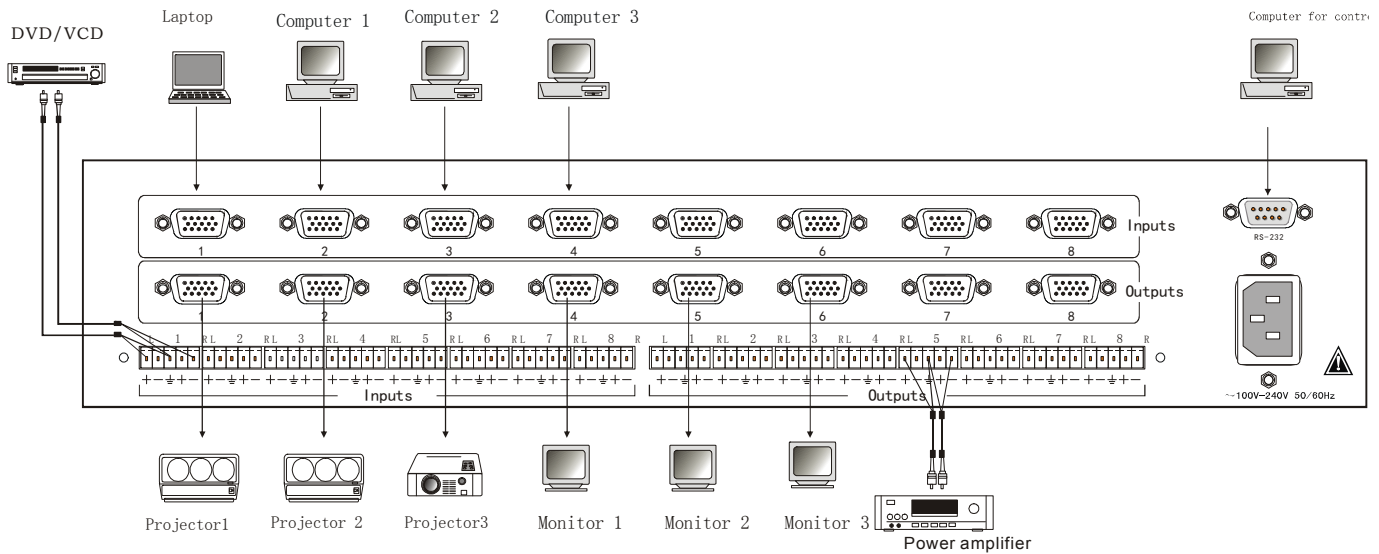

F 6-4 Connection of VGA matrix switcher system

6.4 How to Connect with the VGA I/O Devices

VGA/VGA signal converter is for the VGA signal source without VGA output ports, such as: desktop computers and notebooks. It can convert the VGA signals to VGA signals.

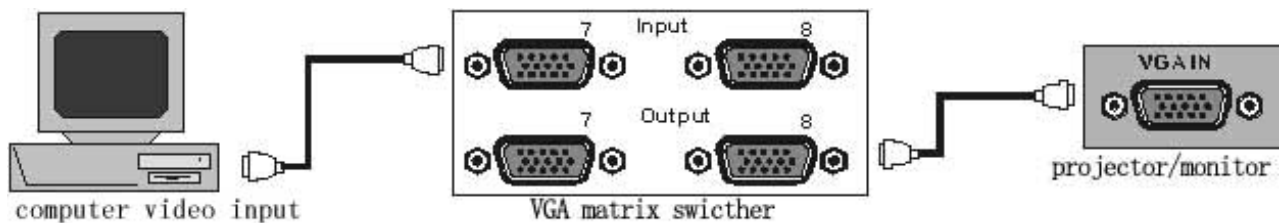

F 6-5 Connection of VGA I/O devices

6.5 Connection of VGA3201 Stack

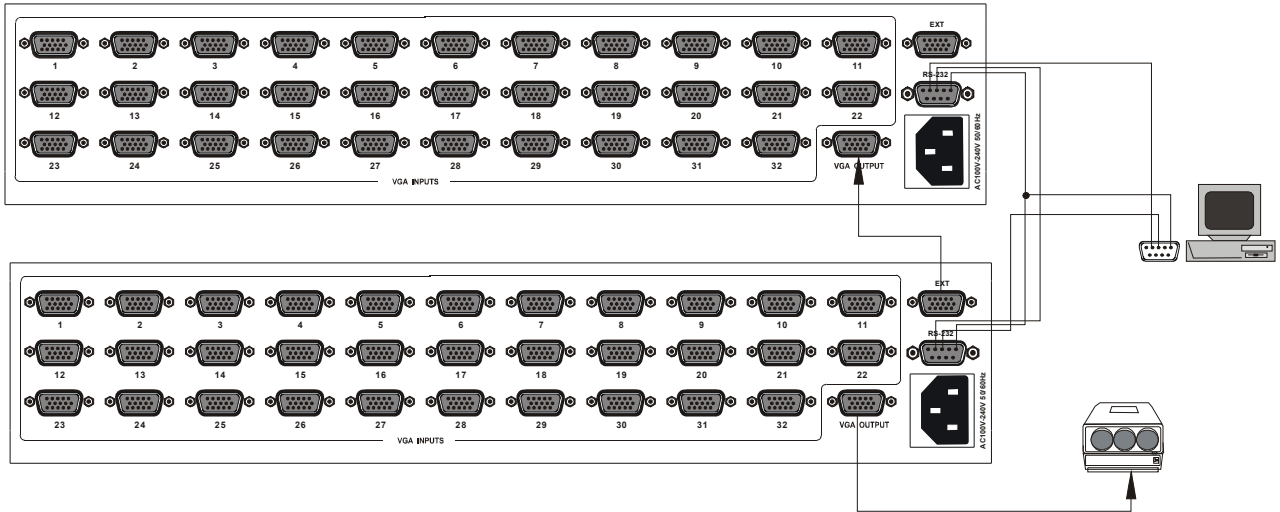

F 6-6 Connection of VGA matrix stack

Sketch maps of stack connection between computer COM port and VGA matrix serials port:

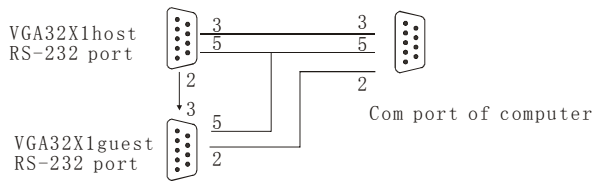

Matrix stack of two VGA3201

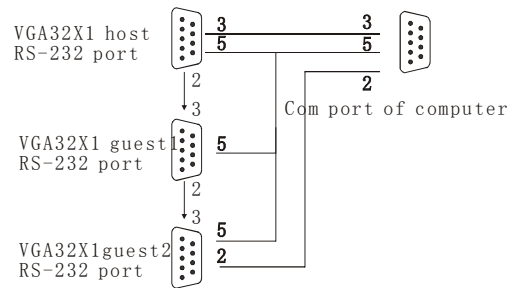

Matrix stack of three VGA3201

Notes:

1. The channel #1 of the first guest matrix should be the channel #33 of the stack matrix system, and the #2 should be the #34, and so on...
2. In this way, three VGA3201 matrixes can be extended to a 9601 matrix stack system.

7. Operation of the Control Panel

7.1 Front Panel Description

7.1.1 Front Panel Description of VGA0404-A

“AV” AV synchronal button: To transfer video and audio signal synchronously by the switcher
 Example: To transfer both the video and the audio signals from input channel No.3 to output channel No.2.

- Operation: Press buttons in this order “3”, “AV”, “2”
- “VIDEO” Video button: To transfer only video signals from input channel to output channel
Example: To transfer video signals from input channel No.2 to output channel No.1.
Operation: Press buttons in this order “2”, “VIDEO”, “1”
- “AUDIO” Audio button: To transfer only audio signals from input channel to output channel
Example: To transfer audio signals from input channel No.2 to output channel No.4.
Operation: Press buttons in this order “2”, “AUDIO”, “4”
- “1,2,3,4” I/O Keypads: Keys to select I/O channels.

7.1.2 Front Panel Description of VGA0801

- “DEMO” Demo button: Press it to auto-switch all the input channels to the output channel.
- “CLOSE” Close button: Press it to switch off the output channel.
Example: To switch off the output channel
Operation: Press buttons in this order “1”, “CLOSE”.
- “LOCK” Lock button: Press it to lock buttons on the front control panel by pressing it for 5 seconds.

Note: Press it for 5 seconds again to unlock the control panel.
- “1,2...8” Input Keypads: Keys to select input channels.

7.1.3 Front Panel Description of VGA3201,VGA0808-A, VGA1608-A

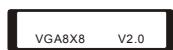

- LCD display: Real time monitor of the operations and status
- “1,2...8” Input Keypads: Keys to select input channels.
- “AV” AV synchronal button: To transfer video and audio signal synchronously by the switcher
Example: To transfer both the video and the audio signals from input channel No.3 to output channel No.6.
Operation: Press buttons in this order “3”, “AV”, “6”, “END”, “ENTER”
- “VIDEO” Video button: To transfer only video signals from input channel to output channel
Example: To transfer video signals from input channel No.3 to output channel No.10.
Operation: Press buttons in this order “3”, “VIDEO”, “1”, “0”, “END”, “ENTER”
- “AUDIO” Audio button: To transfer only audio signals from input channel to output channel
Example: To transfer audio signals from input channel No.12 to output channel No.6.
Operation: Press buttons in this order “1”, “2”, “AUDIO”, “6”, “END”, “ENTER”
- “ / ” Break button: To break different channels in a command
Example: To transfer video and audio signals from input channel No.1 to output channel No.2,13,6 at the same time
Operation: Press buttons in this order “1”, “AV”, “2”, “/”, “1”, “3”, “/”, “6”, “END”, “ENTER”
- “END” Ending command button: To finish inputting a command
- “ENTER” Performance button: To perform a command after inputting it
- “ALL” All button: To transfer an input channel to all output channels or switch off all the output

channels

Example1: To transfer video and audio signals from input channel No.7 to all output channels

Operation: Press buttons in this order “7”, “ALL”

Note: This command need not follow by “END” & “ENTER”

Example2: To transfer all input signals to the corresponding output channels respectively. In another word, to switch to this status: 1->1, 2->2, 3->3, 4->4.....16->16.

Operation: Press buttons in this order “ALL”, “1”

Example3: To switch off all the output channels

Operation: Press buttons in this order “ALL”, “2”

“SAVE” Save button: To save the present operation to a preset command

Example: To save the present operation to the preset command No.2

Operation: Press buttons in this order “SAVE”, “2”

Note: There are altogether 10 preset commands ranged from No.0 to No.10.

“RECALL” Recall button: To recall the preset command

Example: To recall the preset command No.2

Operation: Press buttons in this order “RECALL”, “2”

“CANCEL” Cancel button: To return to the standby status without performing any command

Example: To cancel the input instructions “1”, “AV”, “2”, “END”

Operation: Just press button“CANCEL” after the above inputs

“STATUS” Inquiring status button: To inquire the present status

Example1: To inquire the status of output channel No.7

Operation: Press buttons in this order “7”, “STATUS”

Example2: To inquire the status of all the output channels one by one

Operation: Press only the button “STATUS”

7.2 Command Format of the Switching Operation

With the front control panel, the switcher could be control directly and rapidly by pressing the buttons under below format.

“Input Channel”+“Switching Mode”+“Output Channel 1”+“/”+“Output Channel 2”+“END”+“ENTER”

“Switching Mode”: “AV”, “Audio”, “Video”

“Input Channel”: Fill with the number of input channel to be controlled

“Output Channel”: Fill with the number of output channels to be controlled

7.3 Examples of Operation

Example 1:To transfer video and audio signals from input channel No.1 to output channel No.3,4

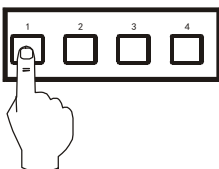

1, Press the button for input channel number “1”
Display feedback on LCD: “1” for the input

channel

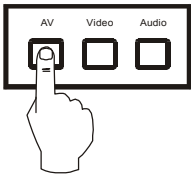

Input Command:
1B

2, Press the button for switching mode "AV"

Display feedback on LCD: "B" for the switching mode of video and audio ("A" for the switching mode of audio only; "V" for the switching mode of video only)

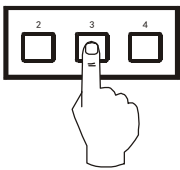

Input Command:
1B3

3, Press the button for the first output channel number "3"

Display feedback on LCD: "3" for the first output channel

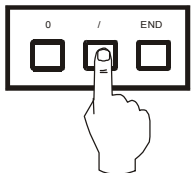

Input Command:
1B3,

4, Press the break button "/"

Display feedback on LCD: " , " for a break between two channels in a command

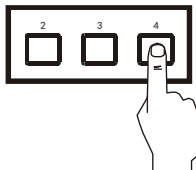

Input Command:
1B3, 4

5, Press the button for the second output channel number "4"

Display feedback on LCD: "4" for the second output channel

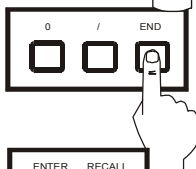

Input Command:
1B3, 4.

6, Press the button "END" to finish the command
Display feedback on LCD: "." for the end of a command

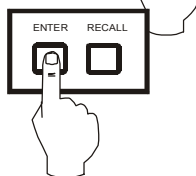

1B3,4.
Switch OK

7. Press the button "ENTER" to perform this command

Display feedback on LCD: "Switch OK" for the successful performance of switching

Example 2: To inquire the status on the output channel No.4

Operation: Press buttons in this order "4", "STATUS"

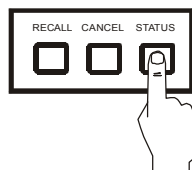
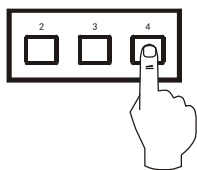

VIDEO: 3 → 4
AUDIO: 2 → 4

Display feedback on LCD: The video signal of output channel No.4 is transferred from the input channel

VGA Matrix Switcher System

No.3 and the audio signal is from the input channel No.2

8. Usage of the Remote Controller (Optional Accessory)



With the optional infrared remote controller, the matrix switcher could be control remotely. Because the function buttons on the remote controller are the same with the ones on the front control panel, the remote controller shares the same control operation and command format with the control panel. Please refer the details in **Chapter 7 Operation of the Control Panel**.

9. Operation of the Switcher Application

9.1 Introduction of SWITCHER 2.0

SWITCHER 2.0 is a matrix switcher control application compatible with switchers with different input and output channels.

9.1.1 About the Application

SWITCHER 2.0 is developed for matrix system test and control. Its running condition is as below:

Operating System: Window98/2000/NT

Memory: At least 32M

Space in hard disk: At least 10M

CD-ROM

1 COM Port at least

9.1.2 Starting the Application

Firstly, connect the matrix switcher and computer via their RS232 ports with the cord supplied in the package. (Please refer to **6.2.2 Connection with Computer** for details).

Secondly, turn on the power of the matrix switcher and computer.

Thirdly, run the application **SWITCHER 2.0** at the computer.

9.2 Functions of the Application

According to practical needs, user can select and operate at different function tabs such as SYSTEM, AUTO, KEYBOARD, CUSTOM CODE, CODE GROUP and SEND/RECEIVE CODE LIST.

The interface of main window is as below:



F 9-1 The interface of main window

9.2.1 Interface Description

In the right hand of the main window, there are 256 buttons standing for the 256 output channels. When clicking on the button, say output 1, the dialogue **OutPort 1** like the graph at right will come up.

“SIGNAL”: Select the switching mode among “AV”, “VIDEO” and “AUDIO”

“INPUT A/V PORT”: Select an input A/V channel

“INPUT AUDIO PORT”: Select an input audio channel

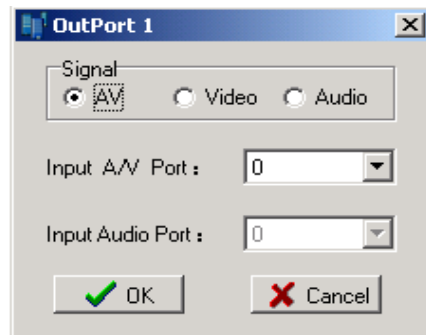

F 9-2

9.2.2 Description of SYSTEM Tab

Startup

Choose SYSTEM Tab from the main window. (F 9-1)

Description

“连接方式”: Select the communication mode between “COM” or “TCP/IP”

“COM”: Select a COM port to control the switcher (if select the “TCP/IP” as the communication mode,

this sub-page will appear as an IP input blank for the address of switcher)

“**Set Password**” : Set the password for the control panel on the Matrix (The password should be an 8 digits number)

“**Unlock Keyboard**” : Unlock the keyboard of the control panel on the Matrix

9.2.3 Description of KEYBOARD Tab

Startup

Choose KEYBOARD Tab from the main window. (F 9-3)

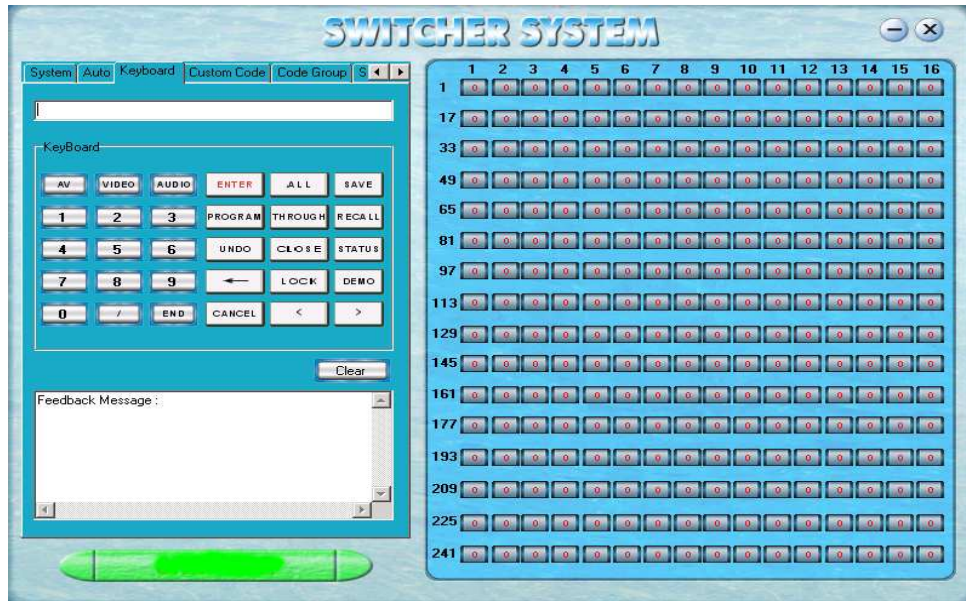

F 9-3 Keyboard tab

Description

Because the function buttons on this tab are the same with the ones on the front control panel, it shares the same control operation and command format with the control panel. Please refer the details in **Chapter 7 Operation of the Control Panel**.

9.2.4 Description of Auto Tab

Startup

Choose the Auto Tab from the main window. (F 9-4)

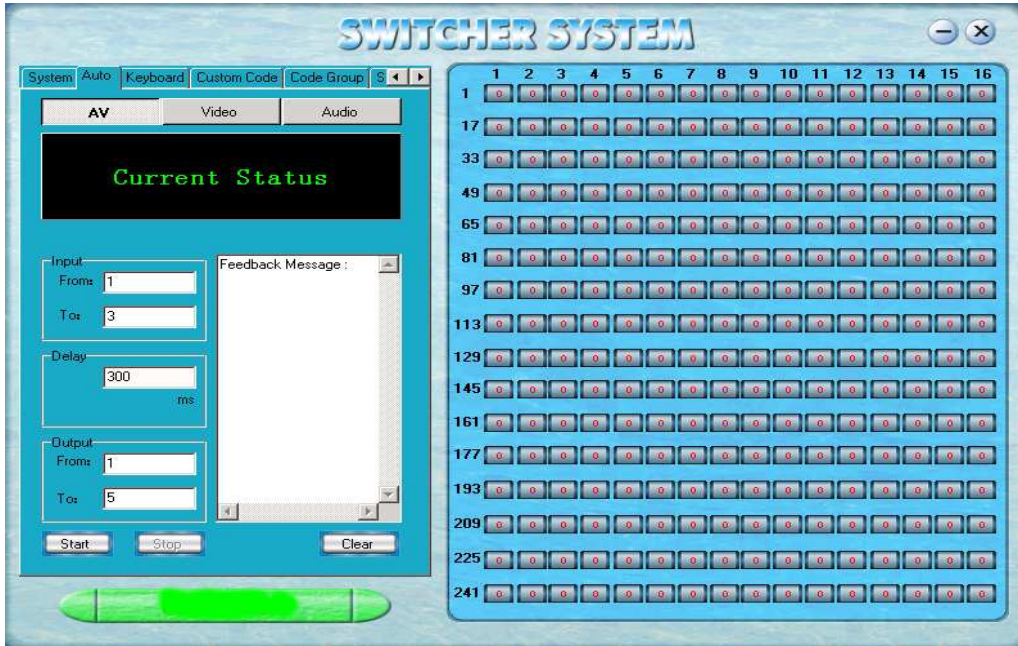

F 9-4 Auto Tab

Description

This function tab is used to test the matrix switcher after connecting it to all the input and output devices. For example, to test the function of an VGA6432 matrix switcher, the Auto Tab is set as below after finishing all the connection.

Switch Mode: "AV"

INPUT: From 1 to 8

OUTPUT: From 1 to 8

Delay: 1000ms (1 second)

When click on the button "START" to perform this test, the matrix switcher will:

Transfer the signals from the input channel No.1 to the output channel No.1-8;

Transfer the signals from the input channel No.2 to the output channel No.1-8;

.....

Transfer the signals from the input channel No.64 to the output channel No.1-8;

This switching test will perform in this way one by one every one second until the test is over.

9.2.5 Description of Custom Code Tab

Startup

Choose the Custom Code Tab from the main window. (F 9-5)

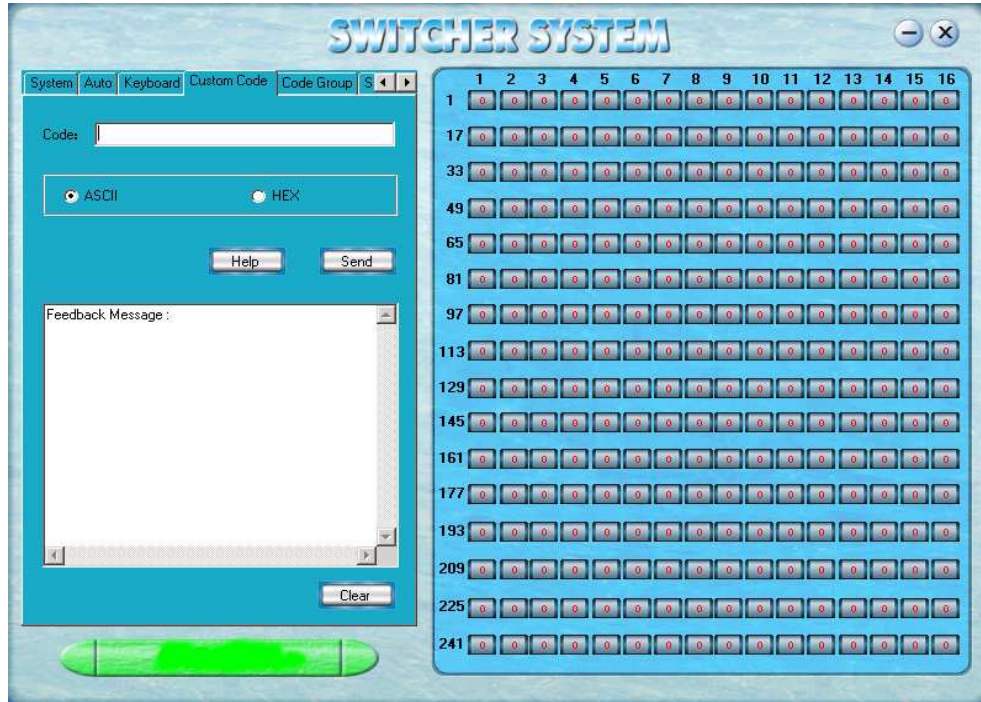

F 9-5 Custom Code Tab

Description

Format: Select the format of command codes between ASCII and HEX (For the format details, please refer to the **Chapter 10. Communication Protocol and Command Codes**)

Help: Click this button to read the explanation of commands

Send: Click this button to send out the command

For example, to transfer the video and audio signals from the input channel No.1 to the output channel No.7, and the audio signals from the input channel No.2 to the output channel No.4, just perform the several steps below.

1. Select the "ASCII" as the command codes format;
2. Input the command codes "1B7.2A4." at the blank of Codes;
3. Click the button "Send" to perform it.

9.2.6 Description of Code Group Tab

Startup

Choose the Code Group Tab from the main window. (F 9-6)

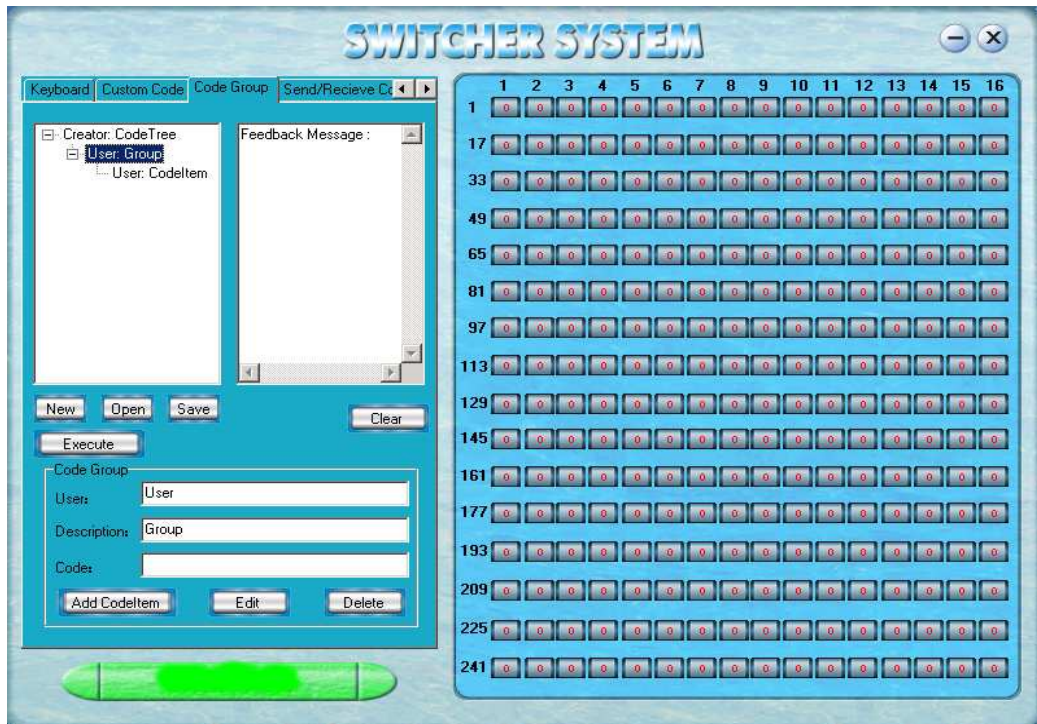

F 9-6 Code Group Tab

Description

New: To new a group of preset commands

Open: To open a group of preset commands

Save: To save the present group of preset commands

Execute: To execute a selected preset command or a selected group of preset commands

Clear: To clear the feedback window

Add CodeItem: To add another new group of preset commands

Edit: To edit the User's name (User), the Group's name (Description), the Code of command (Code)

Delete: To delete the selected group

9.2.7 Description of Send/receive Code List Tab

Startup

Choose the Send/receive Code List Tab from the main window. (F 9-7)



F 9-7 Send/receive Code List Tab

Description

Send List window: A send list of command code

Received List window: A feedback list from the switcher

Clear: To clear the two lists

10. Communication Protocol and Command Codes

With this command system, the application “Switcher 2.00” is able to control and operate the VGA Matrix with remotely.

Communication protocol:

Baud rate: 9600 Data bit: 8 Stop bit: 1 Parity bit: none

Command Types	Command Codes	Functions
System Command	/*Type;	Inquire the models information.
	/+xxxxxxxx;	Rewrite the password of the control panel on the Matrix. The new password, xxxxxxxx, should be an 8 digits number.
	/%Lock;	Lock the keyboard of the control panel on the Matrix.
	/%Unlock;	Unlock the keyboard of the control panel on the Matrix.
	/:BellOff;	Turn off the buzzer.
	/:BellOn;	Turn on the buzzer.
	/^Version;	Inquire the version of software
	/~CREATOR20;	Switch to the CREATOR2.0 command system.
Operation Command (CREATOR2.0 Command System)	[x1]All.	Transfer signals from the input channel [x1] to all output channels
	All#.	Transfer all input signals to the corresponding output channels respectively.
	All\$.	Switch off all the output channels.
	[x1]#.	Transfer signals from the input channel [x1] to the output channel [x1].
	[x1]\$.	Switch off the output channel [x1].
	[x1] V[x2].	Transfer the video signals from the input channel [x1] to the output channel [x2].
	[x1] V[x2],[x3],[x4].	Transfer the video signals from the input channel [x1] to the output channels [x2], [x3] and [x4].
	[x1] A[x2].	Transfer the audio signals from the input channel [x1] to the output channel [x2].
	[x1] A[x2],[x3],[x4].	Transfer the audio signals from the input channel [x1] to the output channels [x2], [x3] and [x4].
	[x1] B[x2].	Transfer both the video and the audio signals from the input channel [x1] to the output channel [x2].
	[x1] B[x2],[x3],[x4].	Transfer both the video and the audio signals from the input channel [x1] to the output channels [x2], [x3] and [x4].
	[x1]P[x2].	Transfer signals from the input channel [x1] to all the output channels in group [x2].

VGA Matrix Switcher System

	[x1]PP[x2],[x3],[x4].	Group the output channels [x2], [x3] and [x4] under the group [x1].
	S[x].	Inquire the output channels in Group[x].
	Status[x1].	Inquire the input channel to the output channel [x1].
	Status.	Inquire the input channel to the output channels one by one.
	Save[Y].	Save the present operation to the preset command [Y]. [Y] ranges from 0 to 9.
	Recall[Y].	Recall the preset command [Y].
	Clear[Y].	Clear the preset command [Y].
	[X1]*[X2]!	Transfer both the video and the audio signals from the input channel [x1] to the output channel [x2].
Compatible Command System	[X1]*[X2]\$	Transfer the audio signals from the input channel [x1] to the output channel [x2].
	[X1]*[X2]%	Transfer the video signals from the input channel [x1] to the output channel [x2].
	[X1]*[X2]&	Transfer the video signals from the input channel [x1] to the output channel [x2].

Note:

- [x1], [x2], [x3] and [x4] are the symbols of input or output channels ranged according to the model of the matrix switcher. If the symbols exceed the effective range, it would be taken as a wrong command.
- In above commands, “[” and “]” are symbols for easy reading and do not need to be typed in actual operation.
- Please remember to end the commands with the ending symbols “.” and “;”.
- The matrix from VGA0801 and VGA3201 only supports the compatible command system.

Detail Examples:

1、 Transfer signals from an input channel to all output channels: [x1]All.

Example: To transfer signals from the input channel No.3 to all output channels

Run Command: “3All.”

2、 Transfer all input signals to the corresponding output channels respectively: All#.

Example: If this command is carried out on an VGA1616-A matrix switcher, the status of it will be:

1->1, 2->2, 3->3, 4->4.....16->16.

3、 Switch off all the output channels: All\$.

Example: After running this command, there will be no signals on all the output channels.

4、 Transfer signals from an input channel to the corresponding output channel: [x]#.

Example: To transfer signals from the input channel No.5 to the output channel No.5.

Run Command: “5#.”

Example: To transfer signals from the input channel No.1,2,3,4 to the corresponding output channel No.1,2,3,4.

Run Command: “1,2,3,4#.”

6,Switch off an output channel: [x]\$.

Example: To switch off the output channel No.5.

Run Command: "5\$."

Example: To switch off the output channel No.1,2,3,4.

Run Command: "1,2,3,4\$."

7,Switch video signals command: [x1] V[x2].

Example: To transfer the video signals from the input channel No.3 to the output channel No.5.

Run Command: "3V5."

Example: To transfer the video signals from the input channel No.3 to the output channel No.8,9,12.

Run Command: "3V8,9,12."

8,Switch audio signals command: [x1] A[x2].

Example: To Transfer the audio signals from the input channel No.10 to the output channel

Run Command: "10A2."

Example: To transfer the audio signals from the input channel No.10 to the output channel No.2,20,30,40.

Run Command: "10A2,20,30,40."

9,Switch both video and audio signals synchronously: [x1] B[x2].

Example: To transfer both the video and the audio signals from the input channel No.120 to the output channel No.12,13,15.

Run Command: "120B12,13,15."

10,Transfer signals to group channels: [x1]P[x2].

Example: After the command "2PP1, 3, 5, 7." was carried out, the command "1P2." would transfer signals from the input channel No.1 to all output channels in Group2 (1, 3, 5, 7). If [x2] was filled with "0", this command will clear the Group[x1]. Please clear the group to be set before grouping it.

11,Group channel command: [x1]PP[x2],[x3],[x4].

Example: To group the output channels No.1,3,5,7 under the Group2.

Run Command: "2PP1, 3, 5, 7."

Notes: In this command, the maximum value of [x1] equals to the maximum output channels the matrix switcher has. To new a Group[x1], the command is "[x1]P0.[x1]PP[x2],[x3],[x4]". To expand the Group[x1], the command is "[x1]PP[x7],[x8],[x9]". Each output channel belongs the only group claims it the latest.

12,Inquire the output channels in Group[x]: S[x].

Example: To inquire the output channels in Group1.

Run Command: "S[1]"

13,Inquire the input channel to the output channel [x]: Status[x].

Example: To inquire the input channel to the output channel No.23.

Run Command: "Status23."

14,Inquire the input channel to the output channels one by one: Status.

Example: To inquire the input channel to the output channels one by one

Run Command: "Status."

15,Save the present operation to the preset command [Y]: Save[Y].

Example: To save the present operation to the preset command No.7.

Run Command: "Save7."

16, Recall the preset command [Y]: Recall[Y].

Example: To recall the preset command No.5.

Run Command: "Recall5."

17, Clear the preset command [Y]: Clear[Y].

Example: To clear the preset command No.5.

Run Command: "Clear5."

11. Technical Specifications

Series	VGA0404-A	VGA8 series	VGA16 series	VGA0801	VGA3201 series
Specifications					
Video					
Models included	VGA0404-A	VGA0802-A VGA0804-A VGA0808-A	VGA1604-A VGA1608-A	VGA0801	VGA3201 VGA6401 VGA9601
Gain	0 dB				
Bandwidth	250MHz (-3dB), fully loaded				
Cross talk sum	-60dB @10 MHz, -39dB @100 MHz				
Switching speed	200 ns (Max)				
Signal type	VGA, VGAS, RGsB, RsGsBs, HDTV, Component video, S-video, Composite video				
Input video					
Connector	Female 15-pin HD				
Signal strength	1V p-p Y component video,S-video, composite video; 0.7V p-p VGA;0.3V p-p R-Y & B-Y component video, S-video				
Maximum/Minimum level	Analog signals: 0.5V ~ 2.0V p-p				
Impedance	75 Ω				
Echo loss	<-40dB@5MHz				
Horizontal frequency response	15 kHz ~ 145 kHz				
Vertical frequency response	30 Hz ~ 170 Hz				
Max error in DC offset	15mV				
Output video					
Connector	Female 15-pin HD				

VGA Matrix Switcher System

Series	VGA0404-A	VGA8 series	VGA16 series	VGA0801	VGA3201 series
Specifications					
Maximum/Minimum level	2.0V p-p				
Impedance	75 Ω				
Echo loss	<-40dB@5MHz				
Max compensation in Dc offset	±5mV				
Sync signal					
Input/output signals	RGBHV, RGBS, RGSB, RsGsBs, Component video, Composite video				
Video system	NTSC 3.58, NTSC 4.43, PAL, SECAM				
Input level	0.5V- 5.0V p-p,: 4.0V p-p normal				
Output level	AGC-TTL: 5Vp-p, unterminated				
Input impedance	510 Ω				
Output impedance	75 Ω				
Maximum transmission delay	Horizontal:90ns Vertical:160ns				
Maximum ascending/descending time	4ns				
Polarity	Straight or subtractive according to input				
Audio signal					
I/O connector	3.8mm with screw , 5 pole				
Gain	0dB				
Frequency respond	20 Hz ~ 20 kHz,				
General harmonic distortion + noise	0.05% @ 1 kHz (under rating voltage)				
S/N	>90dB				
Segregation rate	>80dB @ 1 kHz				
CMRR	>75dB @: 20 Hz ~ 20 kHz				
Signal	Stereo , balanced /unbalanced				
Impedance	Input:>10 kΩ (balanced /unbalanced) Output:50 Ω (unbalanced) , 100 Ω (balanced)				
Maximum input level	+19.5dBu, (balanced /unbalanced)				
Gain error	±0.1dB @20 Hz ~ 20 kHz				
Max output level	+19.5dBu, (balanced /unbalanced)				
Control type					
Serial control port	RS-232, 9-pin FD connector				

Series	VGA0404-A	VGA8 series	VGA16 series	VGA0801	VGA3201 series
Specifications					
Baud rate and protocol	Baud rate: 9600 Data bit: 8 Stop bit: 1 Parity bit: none				
Serial control poling protocol	2 = TX, 3 = RX, 5 = GND				
Control application	Switch 2.0				
Features					
Power supply	100VAC ~ 240VAC, 50/60 Hz, universal international power supply				
Temperature	Storing and operating temperature: -20° ~ +70°C				
Humidity	Storing and operating humidity: 10% ~ 90%				
Size	485(L)X245(W))X445mm(H)	485(L)X260(W))X90mm(H)	485(L)X260(W))X140mm(H)	485(L)X245(W))X445mm(H)	485(L)X260(W))X90mm(H)
weight	1.8kg	3.5kg	4.3kg	1.8kg	3.5kg
MTBF	30,000 hours				
Quality guarantee	1 year free guarantee				

12. Troubleshooting & Maintenance

- 1) When the output image in the destination device connected to the VGA Matrix has ghost, such as the projector output with ghost, please check the projector's setting or try another high quality connection cord.
- 2) When there is a color losing or no video signal output, it may be the unmatched VGA connector order between the input and output end.
- 3) When the remote controller doesn't works:
 - A. Maybe the battery is run out of, please change a new one.
 - B. Maybe the controller is broken, please ask the dealer to fix it.
- 4) When user can not control the VGA Matrix by computer through its COM port, please check the COM port number in the software and make sure the COM port is in good condition.
- 5) When switching , the beeper beeps but without any output image:
 - A. Check with oscilloscope or multimeter if there is any signal at the input end. If there is no signal input, it may be the input connection cord broken or the connectors loosen.
 - B. Check with oscilloscope or multimeter if there is any signal at the output end. If there is no signal output, it may be the output connection cord broken or the connectors loosen.
 - C. Please make sure the destination device is exactly on the controlled output channel
 - D. If it is still the same after the above checking, it may be something wrong in the switcher.

VGA Matrix Switcher System

Please send it to the dealer for fixing.

- 6) If the POWER indicator doesn't work and there is no display on LCD or no respond to any operation, please make sure the power cord connected well.
- 7) If the output image is interfered, please make sure the system is earthed well.
- 8) If the static becomes stronger when connecting the BNC connectors, it may be due to the incorrect earthing of the power supply, Please earth it again correctly, and otherwise it would bring damage to the switcher or shorten its natural life.
- 9) If the beeper beeps, the LCD displaying normally and there is also returning code, but without any output image or audio output.
 - A. Maybe A/V connection broken, please change a new one.
 - B. Maybe the connection cutting-out, please change a new one.
 - C. May be the cord broken, please change a new one.
- 10) If the Matrix can not be controlled by the keys on the front panel, RS232 port or remote controller, the host may has already been broken. Please send it to the dealer for fixing.